

HR3-C100 \varnothing CARBON SEAL DIMENSION TABLE

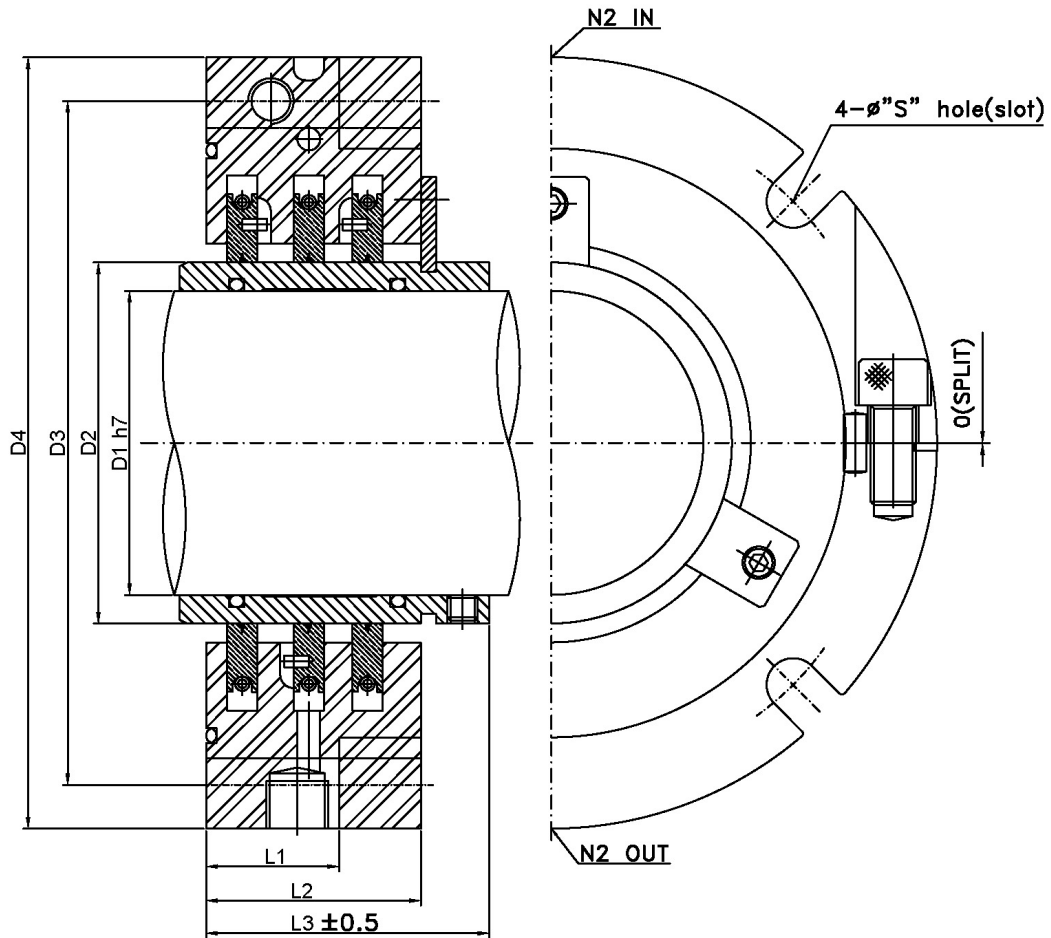

| D1(ϕ) (Shaft O.D) | D2(ϕ) | D3 (P.C.D.) | D4(ϕ) | L1 | L2 | L3 | S(ϕ) | | | |
|----------------------|-------|----------------|-------|----|------|------|------|------|------|----|
| 50/51 | 65 | 165 | 188 | 30 | 17.5 | 63.5 | 14 | | | |
| 55 | 70 | | | | | | | | | |
| 60/61 | 75 | 170 | 193 | | | | | | | |
| 65 | 80 | | | | | | | | | |
| 70/71 | 85 | 175 | 198 | 35 | 21.5 | 74.5 | 15 | | | |
| 75 | 90 | | | | | | | | | |
| 80/81 | 95 | 180 | 203 | | | | | | | |
| 85 | 100 | | | | | | | | | |
| 90/91 | 105 | 185 | 207 | 35 | 21.5 | 74.5 | 15 | | | |
| 95 | 110 | | | | | | | | | |
| 100/101 | 115 | 195 | 217 | | | | 35 | 21.5 | 74.5 | 18 |

※ COG BOOSTER FAN 포함 BLOWER 전용으로 설계